



## WELDED UPRIGHT SHELVING ASSEMBLY INSTRUCTIONS

220-10057-0100

Révision 1

Reviewed by Ana Palencia, Designer.  
Date 2023/07/14

Approved by Eric Marchand, Director of Quality and Engineering  
Signature/Date:2023/07/14



**Energy Door Company**  
[www.energydoorco.com](http://www.energydoorco.com)

180 Arboit Street • L'Assomption • Quebec • J5W 4P5 • CA  
Spare parts – Questions  
☎ 1-844-433-0332

## PROTECTION

- At minimum, two assemblers are required during installation and assembly.
- Use caution when working with sheet metal frames. Wear appropriate PPE (personal protective equipment such as gloves, safety glasses, and arm guards).

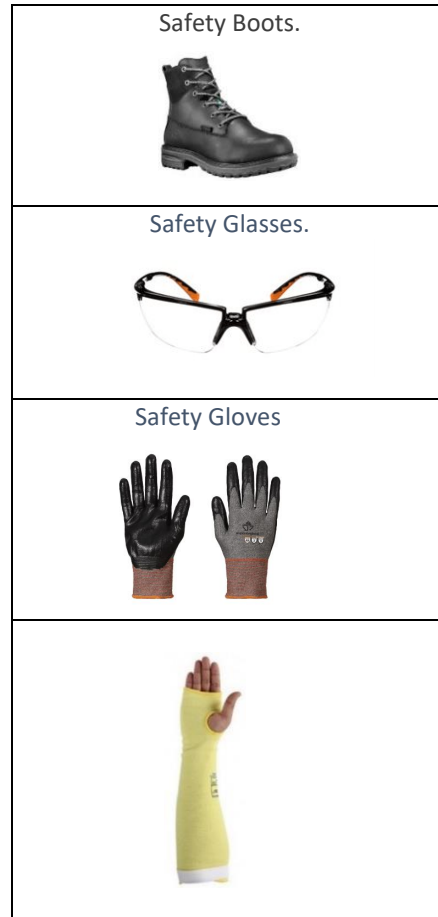

- Insert shelving components on the bottom first and work towards the top.
- Make sure there is enough room for assembling before getting started.
- Install components only as instructed.
- Do not climb or stand on shelves.



| <b>WELDED UPRIGHT SHELVING ASSEMBLY INSTRUCTIONS</b>   |  |
|--|--|
| 220-10057-0100   | Révision 1   |
| Reviewed by Ana Palencia, Designer.<br>Date 2023/07/14   | Approved by Eric Marchand, Director of Quality and Engineering<br>Signature/Date:2023/07/14                      |
|  <p><b>Energy Door Company</b><br/><a href="http://www.energydoorco.com">www.energydoorco.com</a></p> | <p>180 Arboit Street • L'Assomption • Quebec • J5W 4P5 • CA<br/>Spare parts – Questions<br/>☎ 1-844-433-0332</p> |

**Terms:**

- Post (Upright): Vertically orientated component located at 4 corners of Shelving Unit.
- Side Standards: Ends of Shelving Units comprised of 2 posts and 2 welded supports each.
- Cross members: Horizontally mounted components that connect two side standards and support Shelves.
- Angle Iron Cross Member: Cross member made up of angle iron and two end plates.
- Foot Plate: Plate welded to bottom of posts for anchoring or levelers.
- Mullion Bracket: L-shaped bracket that connects the Side Standards to the cooler wall.
- Runner: Hook (4 per) on shelves that sit in holes on the posts and supports each shelf.
- Stand-A-Lone: Complete unit consisting of side standards, cross members, shelves, and mullion brackets. Sits directly behind the cooler door.
- Line-Up: Assembly of Multiple Stand-A-Lone Units sharing common Side Standards.
- Leveler: Threaded Foot with rubber bottom used to level out the welded upright.
- Lane Divider: Wire assembly with welded clip used to divider product on each shelf.
- Perimeter Guard: Wire assembly that hooks in to each post and supports product horizontally.
- Slip Sheet: Plastic sheet with grooves that sits on top of shelf to help product slide to the front of each inclined shelf.
- Leveler & Fastener Kit: Kit containing two levelers and nuts to fit and fasteners to attach each cross member to Side Standards and Mullion brackets to wall.
- Super Shelf: 30x36, 30x43, or 30x60 Shelf, reinforced with 6 runner wires for versatility.

| <b>WELDED UPRIGHT SHELVING ASSEMBLY INSTRUCTIONS</b>   |  |
|--|--|
| 220-10057-0100   | Révision 1   |
| Reviewed by Ana Palencia, Designer.<br>Date 2023/07/14   | Approved by Eric Marchand, Director of Quality and Engineering<br>Signature/Date:2023/07/14                      |
|  <p><b>Energy Door Company</b><br/><a href="http://www.energydoorco.com">www.energydoorco.com</a></p> | <p>180 Arboit Street • L'Assomption • Quebec • J5W 4P5 • CA<br/>Spare parts – Questions<br/>☎ 1-844-433-0332</p> |

- Standard 30 inch shelf: EDC standard shelf with 2 runners (1 front, 1 back). 30 inch wide x 24, 27, or 30 inch deep.
- Double wide shelf: 48 or 60 inch wide shelf with sheet metal braces for added strength and sheet metal runners.

| <b>WELDED UPRIGHT SHELVING ASSEMBLY INSTRUCTIONS</b>   |  |
|--|--|
| 220-10057-0100   | Révision 1   |
| Reviewed by Ana Palencia, Designer.<br>Date 2023/07/14   | Approved by Eric Marchand, Director of Quality and Engineering<br>Signature/Date:2023/07/14                      |
|  <p><b>Energy Door Company</b><br/><a href="http://www.energydoorco.com">www.energydoorco.com</a></p> | <p>180 Arboit Street • L'Assomption • Quebec • J5W 4P5 • CA<br/>Spare parts – Questions<br/>☎ 1-844-433-0332</p> |

Sizes and Quantity of Components vary depending on model ordered. (See page 8 for Variations currently offered).

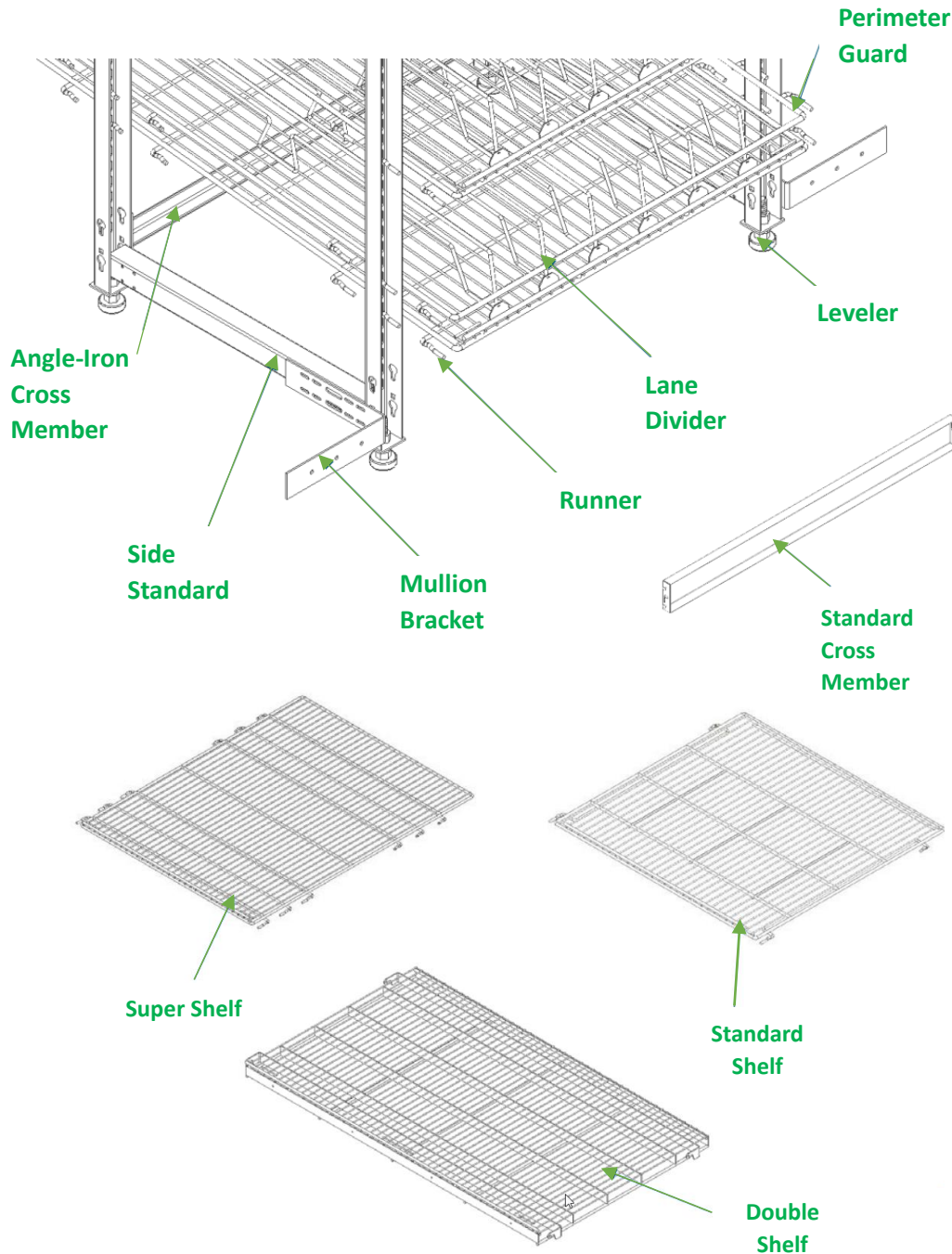

## WELDED UPRIGHT SHELVING ASSEMBLY INSTRUCTIONS

220-10057-0100

Révision 1

Reviewed by Ana Palencia, Designer.  
Date 2023/07/14

Approved by Eric Marchand, Director of Quality and Engineering  
Signature/Date:2023/07/14



**Energy Door Company**  
[www.energydoorco.com](http://www.energydoorco.com)

180 Arboit Street • L'Assomption • Quebec • J5W 4P5 • CA  
Spare parts – Questions  
☎ 1-844-433-0332

**Getting Started:**

What you will need:

- Tools o 7mm Wrench/Socket x 2 o 8mm Socket (for Drill) o 10mm Wrench/Socket x 2 o Drill o Ratchet
- Room for Assembly, preferably, 12 ft x 12 ft area at minimum.
- All necessary components

Step 1) To begin, lay one Side Standard on its side as shown.



Step 2) Add levelers by screwing them into foot plates on each post. Turning the leveler clockwise (facing bottom of base plate) will tighten and counter clockwise to loosen. Make sure you tighten tensioning nut snug to the bottom of the post.

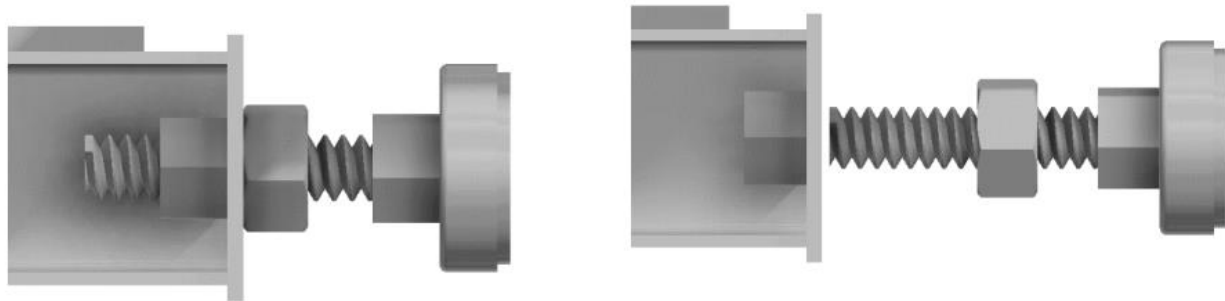

## WELDED UPRIGHT SHELVING ASSEMBLY INSTRUCTIONS

220-10057-0100

Révision 1

Reviewed by Ana Palencia, Designer.  
Date 2023/07/14

Approved by Eric Marchand, Director of Quality and Engineering  
Signature/Date:2023/07/14



**Energy Door Company**  
[www.energydoorco.com](http://www.energydoorco.com)

180 Arboit Street • L'Assomption • Quebec • J5W 4P5 • CA  
Spare parts – Questions  
☎ 1-844-433-0332

Step 3) Stand Side Standard up as shown.

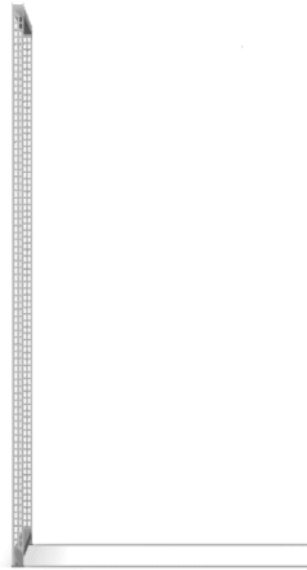

Step 4) Next, attach the first cross member.

If ordered Cross Members are Angle Iron, line up top and bottom holes so that the Open Side of the angle is facing inward, as shown. Then take 2 M6 nuts, 2 lock washers and 2 M6 bolts to fasten to the Side Standard using 10 mm wrench/socket.

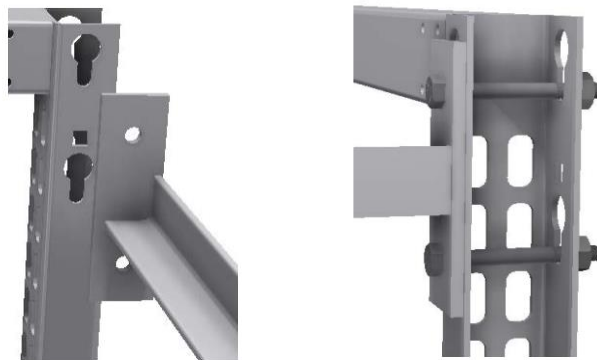

## WELDED UPRIGHT SHELVING ASSEMBLY INSTRUCTIONS

220-10057-0100

Révision 1

Reviewed by Ana Palencia, Designer.  
Date 2023/07/14

Approved by Eric Marchand, Director of Quality and Engineering  
Signature/Date:2023/07/14



**Energy Door Company**  
[www.energydoorco.com](http://www.energydoorco.com)

180 Arboit Street • L'Assomption • Quebec • J5W 4P5 • CA  
Spare parts – Questions  
☎ 1-844-433-0332

If ordered Cross Members are Standard, insert studs into wide holes in cross members, lower into bottom holes and use 10mm wrench/socket to fasten 1 M6 nut, 1 lock washer and 1 M6 bolt to the Side standard.

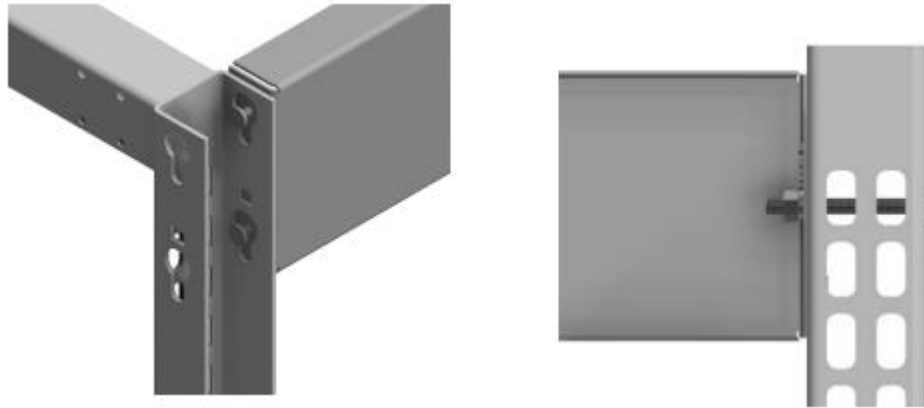

Step 5) Next, take another cross member and do the same until you have the Desired Pattern/Number of Cross members. For example, shown below is top back and bottom back.

\*Note: Depending on which shelf you are using, Front and back will be different. For Super Shelves and Standard Shelves, Front of the shelf will be the open end of the Side Standard. For Double Wide shelves, the closed end will be the front.\*



## WELDED UPRIGHT SHELVING ASSEMBLY INSTRUCTIONS

220-10057-0100

Révision 1

Reviewed by Ana Palencia, Designer.  
Date 2023/07/14

Approved by Eric Marchand, Director of Quality and Engineering  
Signature/Date:2023/07/14



**Energy Door Company**  
[www.energydoorco.com](http://www.energydoorco.com)

180 Arboit Street • L'Assomption • Quebec • J5W 4P5 • CA  
Spare parts – Questions  
☎ 1-844-433-0332



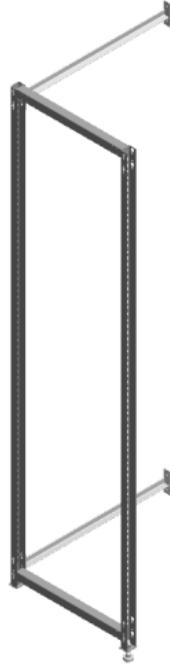

Step 6) Now take another Side Standard and attach it to each of the Cross Members, lining up corresponding holes, and/or studs, and fastening as in Step 3 with M6 bolts, nuts and washers from leveler kit.

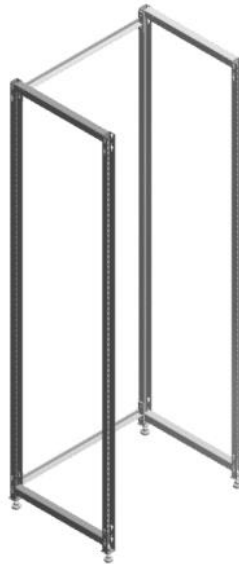

**\*Remember to adjust Levelers when necessary during assembly.**

| <b>WELDED UPRIGHT SHELVING ASSEMBLY INSTRUCTIONS</b>   |  |
|--|--|
| 220-10057-0100   | Révision 1   |
| Reviewed by Ana Palencia, Designer.<br>Date 2023/07/14   | Approved by Eric Marchand, Director of Quality and Engineering<br>Signature/Date:2023/07/14                      |
|  <p><b>Energy Door Company</b><br/><a href="http://www.energydoorco.com">www.energydoorco.com</a></p> | <p>180 Arboit Street • L'Assomption • Quebec • J5W 4P5 • CA<br/>Spare parts – Questions<br/>☎ 1-844-433-0332</p> |

Step 7) Add additional Side Standards to the unit if needed based on the number of Doors ordered.

With the Welded Upright unit standing up, attach another set of cross members and fasten as in Steps 3-4.

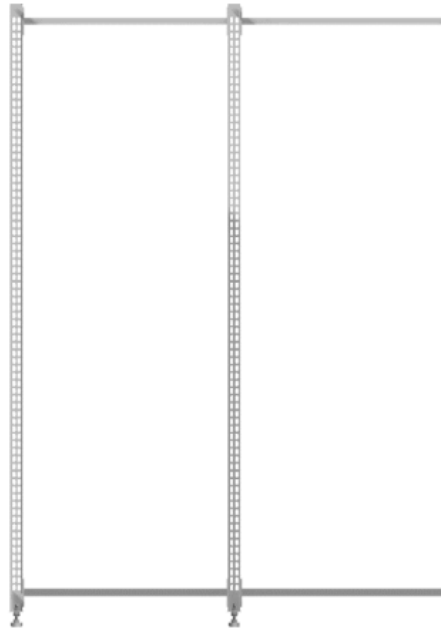

Step 8) Next, add another side standard like in step 4, but add the levelers to the side before attaching to the rest of the Welded Upright.



## WELDED UPRIGHT SHELVING ASSEMBLY INSTRUCTIONS

220-10057-0100

Révision 1

Reviewed by Ana Palencia, Designer.  
Date 2023/07/14

Approved by Eric Marchand, Director of Quality and Engineering  
Signature/Date:2023/07/14



**Energy Door Company**  
[www.energydoorco.com](http://www.energydoorco.com)

180 Arboit Street • L'Assomption • Quebec • J5W 4P5 • CA  
Spare parts – Questions  
☎ 1-844-433-0332

Step 9) Repeat these steps until you have completed enough for all the doors. For example, 3 Doors Line-up shown below.

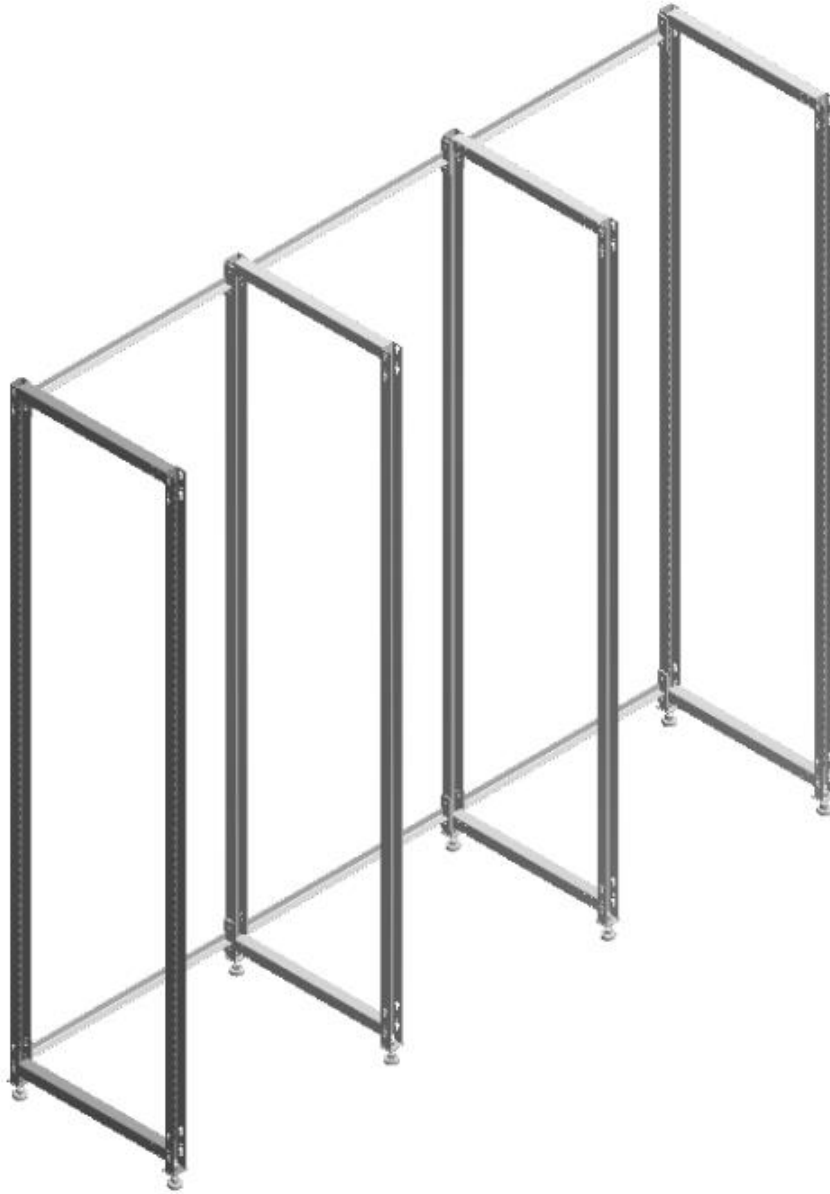

## WELDED UPRIGHT SHELVING ASSEMBLY INSTRUCTIONS

220-10057-0100

Révision 1

Reviewed by Ana Palencia, Designer.  
Date 2023/07/14

Approved by Eric Marchand, Director of Quality and Engineering  
Signature/Date:2023/07/14



**Energy Door Company**  
[www.energydoorco.com](http://www.energydoorco.com)

180 Arboit Street • L'Assomption • Quebec • J5W 4P5 • CA  
Spare parts – Questions  
☎ 1-844-433-0332

**Mullion Bracket Installation:**

1) Determine the space needed between the Cooler Wall and the Side Standard. Starting with Bottom L-Bracket, line up Slots in L-Bracket with Holes on Side Standard.



2) With one washer already on each M4 bolt, insert 2 bolts through the Slots.

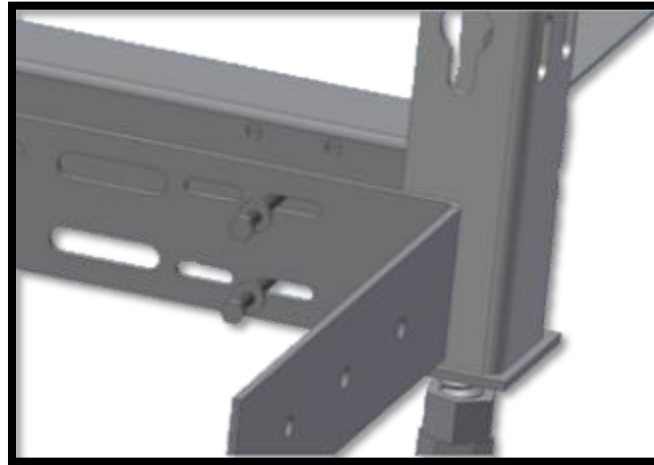

## WELDED UPRIGHT SHELVING ASSEMBLY INSTRUCTIONS

220-10057-0100

Révision 1

Reviewed by Ana Palencia, Designer.  
Date 2023/07/14

Approved by Eric Marchand, Director of Quality and Engineering  
Signature/Date:2023/07/14



**Energy Door Company**  
[www.energydoorco.com](http://www.energydoorco.com)

180 Arboit Street • L'Assomption • Quebec • J5W 4P5 • CA  
Spare parts – Questions  
☎ 1-844-433-0332

3) Place two washers on each bolt before inserting bolts through the holes in the Standard.



4) Bolts should come completely through the tube. Install M4 Nuts on to each bolt and tighten using 7mm wrenches/sockets.

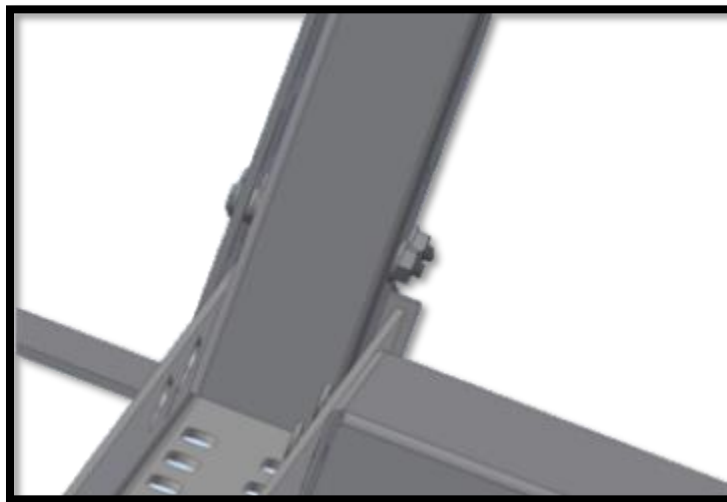

## WELDED UPRIGHT SHELVING ASSEMBLY INSTRUCTIONS

220-10057-0100

Révision 1

Reviewed by Ana Palencia, Designer.  
Date 2023/07/14

Approved by Eric Marchand, Director of Quality and Engineering  
Signature/Date:2023/07/14



**Energy Door Company**  
[www.energydoorco.com](http://www.energydoorco.com)

180 Arboit Street • L'Assomption • Quebec • J5W 4P5 • CA  
Spare parts – Questions  
☎ 1-844-433-0332

5) Use Drill with 8mm socket and #12-11 Sheet Metal Screws to fasten Welded Upright to Cooler Wall.

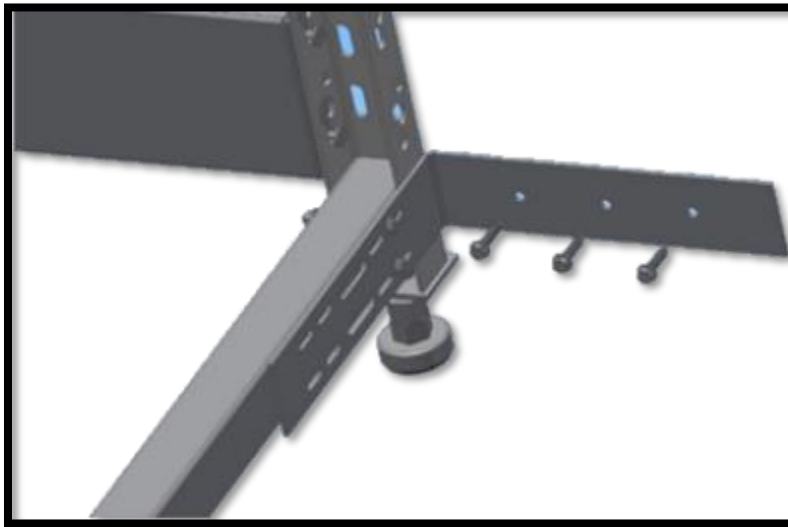

6) Repeat steps 1-5 until each Standard has desired amount of Mullion Brackets.

### WELDED UPRIGHT SHELVING ASSEMBLY INSTRUCTIONS

|  |  |
|--|--|
| 220-10057-0100   | Révision 1   |
| Reviewed by Ana Palencia, Designer.<br>Date 2023/07/14   | Approved by Eric Marchand, Director of Quality and Engineering<br>Signature/Date:2023/07/14                      |
|  <p><b>Energy Door Company</b><br/><a href="http://www.energydoorco.com">www.energydoorco.com</a></p> | <p>180 Arboit Street • L'Assomption • Quebec • J5W 4P5 • CA<br/>Spare parts – Questions<br/>☎ 1-844-433-0332</p> |

## **SHELVING INSTALLATION**

For Super Shelves

- 1) Start by taking a shelf with the back side against your body (The hooks should be pointing towards the front of the cooler) and rotate it 30 degrees. ALWAYS START WITH BOTTOM SHELF.

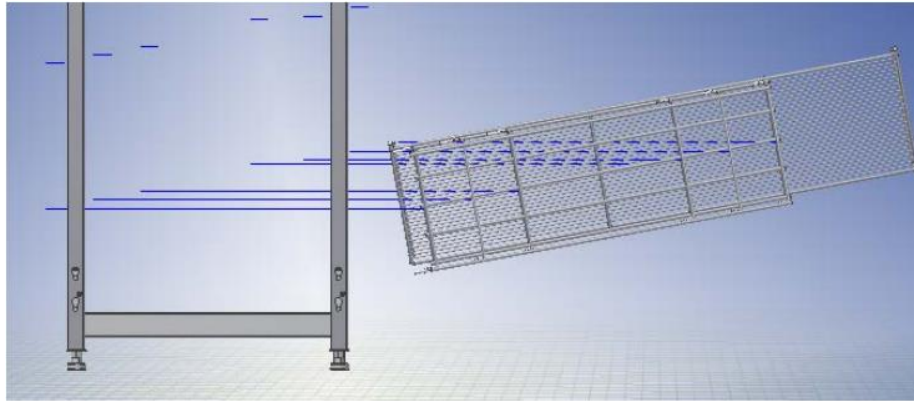

- 2) Next slide the shelf between the two sides until it reaches the space before the desired hook.



## **WELDED UPRIGHT SHELVING ASSEMBLY INSTRUCTIONS**

220-10057-0100

Révision 1

Reviewed by Ana Palencia, Designer.  
Date 2023/07/14

Approved by Eric Marchand, Director of Quality and Engineering  
Signature/Date:2023/07/14



**Energy Door Company**  
[www.energydoorco.com](http://www.energydoorco.com)

180 Arboit Street • L'Assomption • Quebec • J5W 4P5 • CA  
Spare parts – Questions  
☎ 1-844-433-0332

Note: For best results follow the below guide.

30 INCH DEEP SHELVING TO BE INSTALLED ON 1st HOOK.

36 INCH DEEP SHELVING TO BE INSTALLED ON 2nd HOOK.

43 INCH DEEP SHELVING TO BE INSTALLED ON 3rd HOOK.

- 3) Rotate the shelf until flat and line up the hooks. Insert the hooks into the appropriate alignment, making sure the shelf is hooked evenly on both sides.

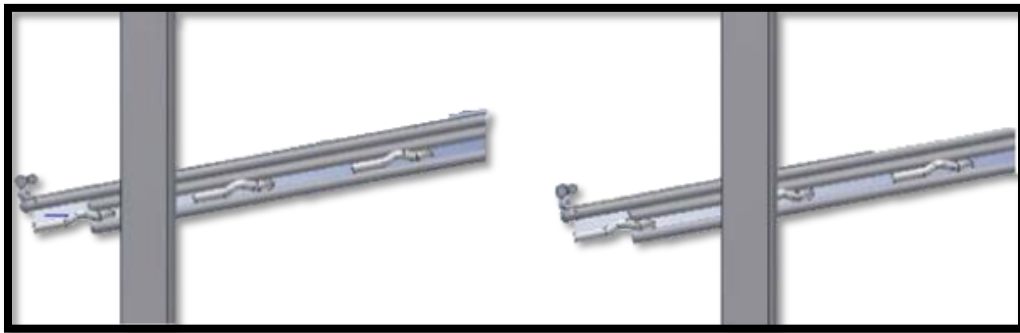

- 4) Repeat Steps 1 thru 3 for the remaining shelves using the space needed for product.

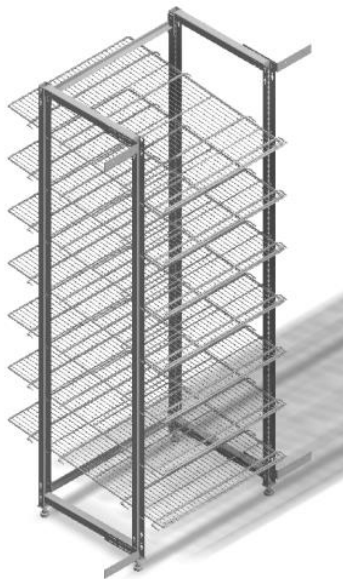

## WELDED UPRIGHT SHELVING ASSEMBLY INSTRUCTIONS

220-10057-0100

Révision 1

Reviewed by Ana Palencia, Designer.  
Date 2023/07/14

Approved by Eric Marchand, Director of Quality and Engineering  
Signature/Date:2023/07/14



**Energy Door Company**  
[www.energydoorco.com](http://www.energydoorco.com)

180 Arboit Street • L'Assomption • Quebec • J5W 4P5 • CA  
Spare parts – Questions  
☎ 1-844-433-0332



For 48" or 60" Double Wide Shelving 1) From the back side (Open end, with the closed in facing the door), bring the Shelf in at an angle between the two Standards.

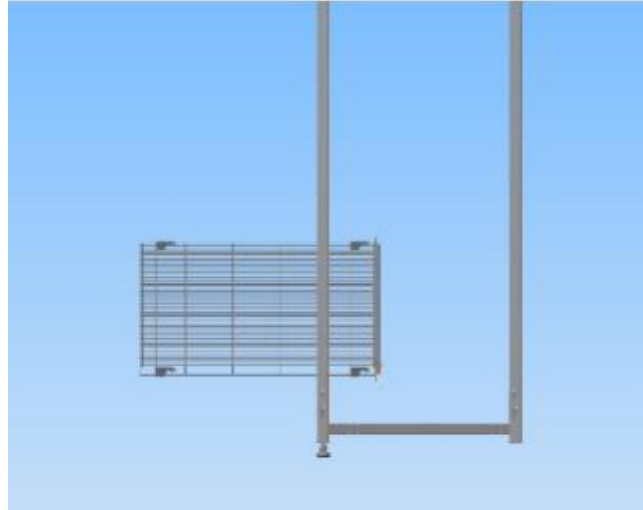

2) Find the desired Slots for the front two notches (Starting with the bottom shelf first). Insert the tip of the Notches into the slots.

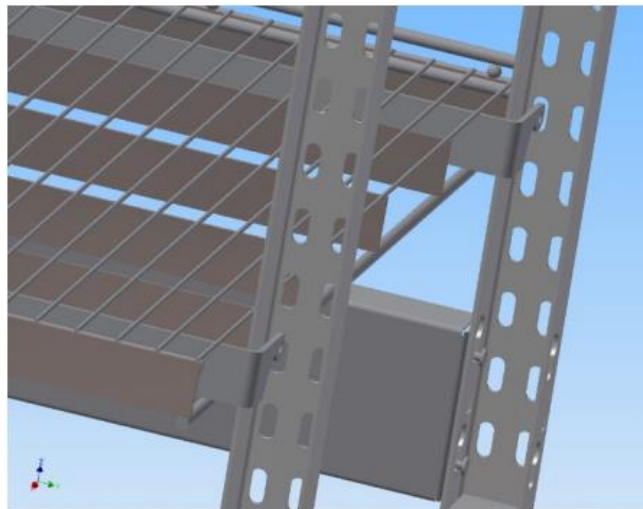

## WELDED UPRIGHT SHELVING ASSEMBLY INSTRUCTIONS

220-10057-0100

Révision 1

Reviewed by Ana Palencia, Designer.  
Date 2023/07/14

Approved by Eric Marchand, Director of Quality and Engineering  
Signature/Date:2023/07/14



**Energy Door Company**  
[www.energydoorco.com](http://www.energydoorco.com)

180 Arboit Street • L'Assomption • Quebec • J5W 4P5 • CA  
Spare parts – Questions  
☎ 1-844-433-0332

3) Find the desired Slots for the back two notches and insert all 4 corners.

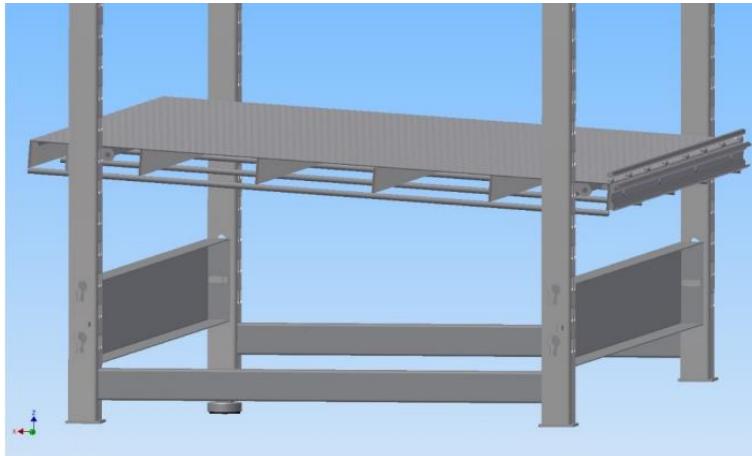
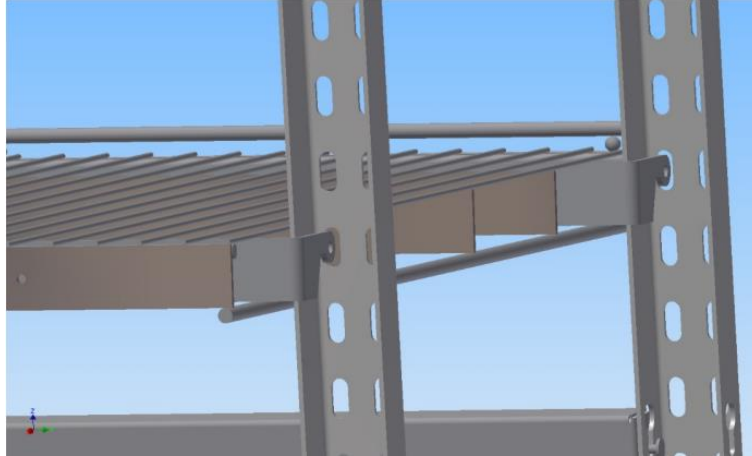

## WELDED UPRIGHT SHELVING ASSEMBLY INSTRUCTIONS

220-10057-0100

Révision 1

Reviewed by Ana Palencia, Designer.  
Date 2023/07/14

Approved by Eric Marchand, Director of Quality and Engineering  
Signature/Date:2023/07/14



**Energy Door Company**  
[www.energydoorco.com](http://www.energydoorco.com)

180 Arboit Street • L'Assomption • Quebec • J5W 4P5 • CA  
Spare parts – Questions  
☎ 1-844-433-0332

- 4) Insert Clevis Pins into Front Right and Back Left or Front Left and Back Right .250" Notched Holes. Then secure Clevis pins with Hitch Pins and shown to secure the Shelf.

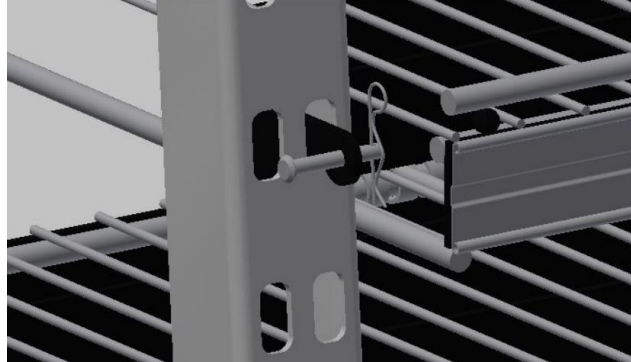

- 5) Repeat Steps 1-4 until all shelves are installed.



### WELDED UPRIGHT SHELVING ASSEMBLY INSTRUCTIONS

220-10057-0100

Révision 1

Reviewed by Ana Palencia, Designer.  
Date 2023/07/14

Approved by Eric Marchand, Director of Quality and Engineering  
Signature/Date:2023/07/14



**Energy Door Company**  
[www.energydoorco.com](http://www.energydoorco.com)

180 Arboit Street • L'Assomption • Quebec • J5W 4P5 • CA  
Spare parts – Questions  
☎ 1-844-433-0332

## ACCESSORIES

### LANE DIVIDER

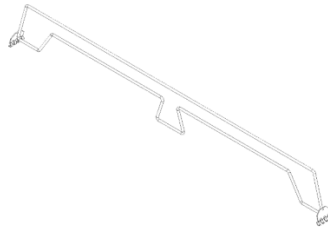

To install a lane divider, use the retainer wire of the shelf getting the divider. Snap one end of the divider clip on the front of the rack as shown.

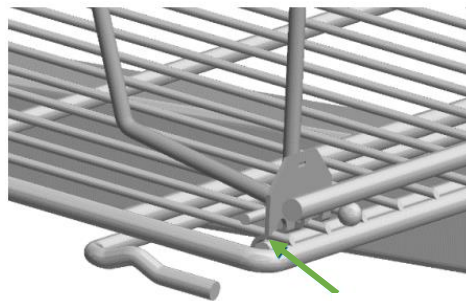

**Retainer Wire**

Lower the Divider parallel with the shelf and bow the divider slightly inward so that the back clip will snap onto the back Frame wire.

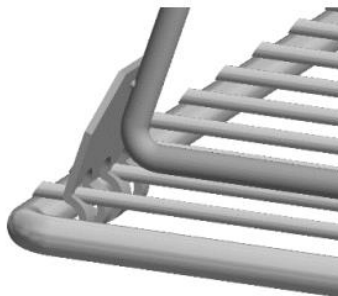

Repeat until Desired number of Dividers are installed.

## WELDED UPRIGHT SHELVING ASSEMBLY INSTRUCTIONS

220-10057-0100

Révision 1

Reviewed by Ana Palencia, Designer.  
Date 2023/07/14

Approved by Eric Marchand, Director of Quality and Engineering  
Signature/Date:2023/07/14



**Energy Door Company**  
[www.energydoorco.com](http://www.energydoorco.com)

180 Arboit Street • L'Assomption • Quebec • J5W 4P5 • CA  
Spare parts – Questions  
☎ 1-844-433-0332

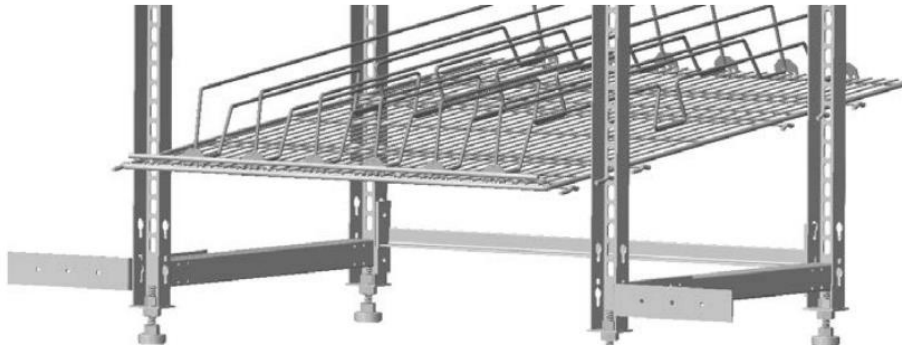

## Perimeter Guard

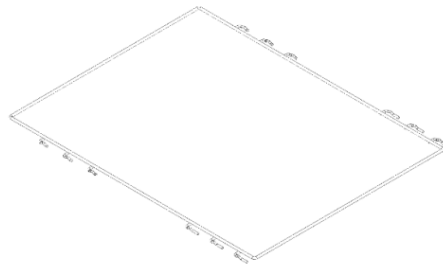

Install Perimeter Guards (1 per shelf) much the same as a shelf. Line up the runners with the desired slots on the post, usually 1 to 2 slots above those used by the shelf.

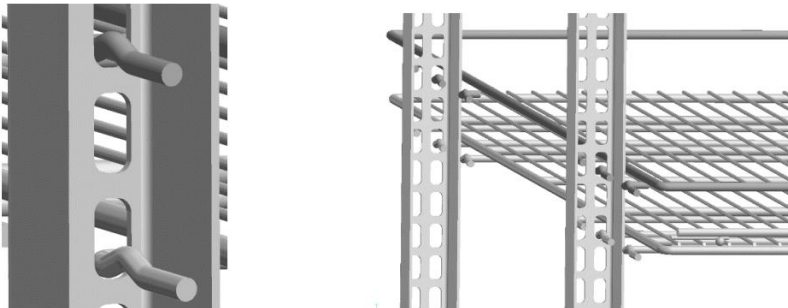

\*Repeat for remaining shelves.

## WELDED UPRIGHT SHELVING ASSEMBLY INSTRUCTIONS

220-10057-0100

Révision 1

Reviewed by Ana Palencia, Designer.  
Date 2023/07/14

Approved by Eric Marchand, Director of Quality and Engineering  
Signature/Date:2023/07/14



**Energy Door Company**  
[www.energydoorco.com](http://www.energydoorco.com)

180 Arboit Street • L'Assomption • Quebec • J5W 4P5 • CA  
Spare parts – Questions  
☎ 1-844-433-0332

## ***Slip Sheet***

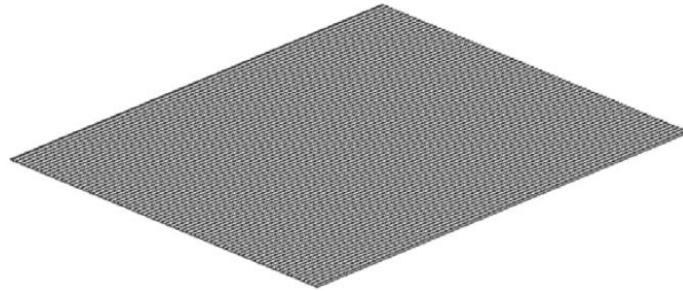

Install Slip sheets by placing sheets (notched side up) on top of shelf behind the ball wire and centered left to right on each shelf. If using Double Wide Shelving, place slip sheet behind the slip sheet wires.

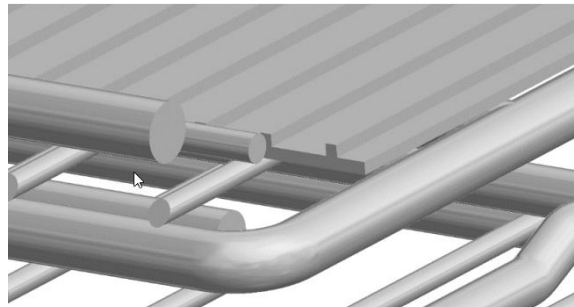

\* Repeat for remaining shelves.

## WELDED UPRIGHT SHELVING ASSEMBLY INSTRUCTIONS

220-10057-0100

Révision 1

Reviewed by Ana Palencia, Designer.  
Date 2023/07/14

Approved by Eric Marchand, Director of Quality and Engineering  
Signature/Date:2023/07/14



**Energy Door Company**  
[www.energydoorco.com](http://www.energydoorco.com)

180 Arboit Street • L'Assomption • Quebec • J5W 4P5 • CA  
Spare parts – Questions  
☎ 1-844-433-0332

**Warranty**

Energy Door Company warrants that the product manufactured by it shall conform to the description in this proposal or any proposal made. In the event that any part(s) shall fail within the first thirty (30) days from date of shipment receipt due to defects in material or workmanship, Energy Door Company shall at its option, repair or replace F.O.B. shipping point, such defective part(s). The warranty obligations of Energy Door Company with respect to products not manufactured by EDC shall conform to and be limited to the warranty actually extended to EDC by its supplier(s).

The defective part(s) shall be returned to Energy Door Company, freight prepaid, unless otherwise directed by Energy Door Company. This warranty shall be exclusive and Energy Door Company makes no warranty of merchantability or warranties of any other kind express or implied which extend beyond this warranty. Energy Door Company is liability for any and all losses and damages to purchaser resulting from defective parts of equipment shall in no event exceed the cost of repair or replacement, F.O.B. shipping point of defective parts or equipment. In no event shall Nashville Wire Products be liable for incidental or consequential damages of any kind or nature whatsoever.

**Disclaimer**

Energy Door Company accepts no liability for damages resulting from any of the following actions:

- (1) The improper assembly and/or installation of the shelving assembly,
- (2) Failure to maintain the system free of abuse beyond what can reasonably be considered ordinary wear and tear.
- (3) Any use which goes beyond the intended purposes including but not limited to the following: climbing and improper loading.

**Proprietary and Confidential**

The information contained in these instructions are the sole property of Energy Door Company and reproduction in part or as a whole, or use of the information contained herein, without the written permission of Energy Door Company is prohibited.

|  |  |
|--|--|
| <b>WELDED UPRIGHT SHELVING ASSEMBLY INSTRUCTIONS</b>   |  |
| 220-10057-0100   | Révision 1   |
| Reviewed by Ana Palencia, Designer.<br>Date 2023/07/14   | Approved by Eric Marchand, Director of Quality and Engineering<br>Signature/Date:2023/07/14                      |
|  <p><b>Energy Door Company</b><br/><a href="http://www.energydoorco.com">www.energydoorco.com</a></p> | <p>180 Arboit Street • L'Assomption • Quebec • J5W 4P5 • CA<br/>Spare parts – Questions<br/>☎ 1-844-433-0332</p> |