

### Typical Perimeter Mount Frame Installation

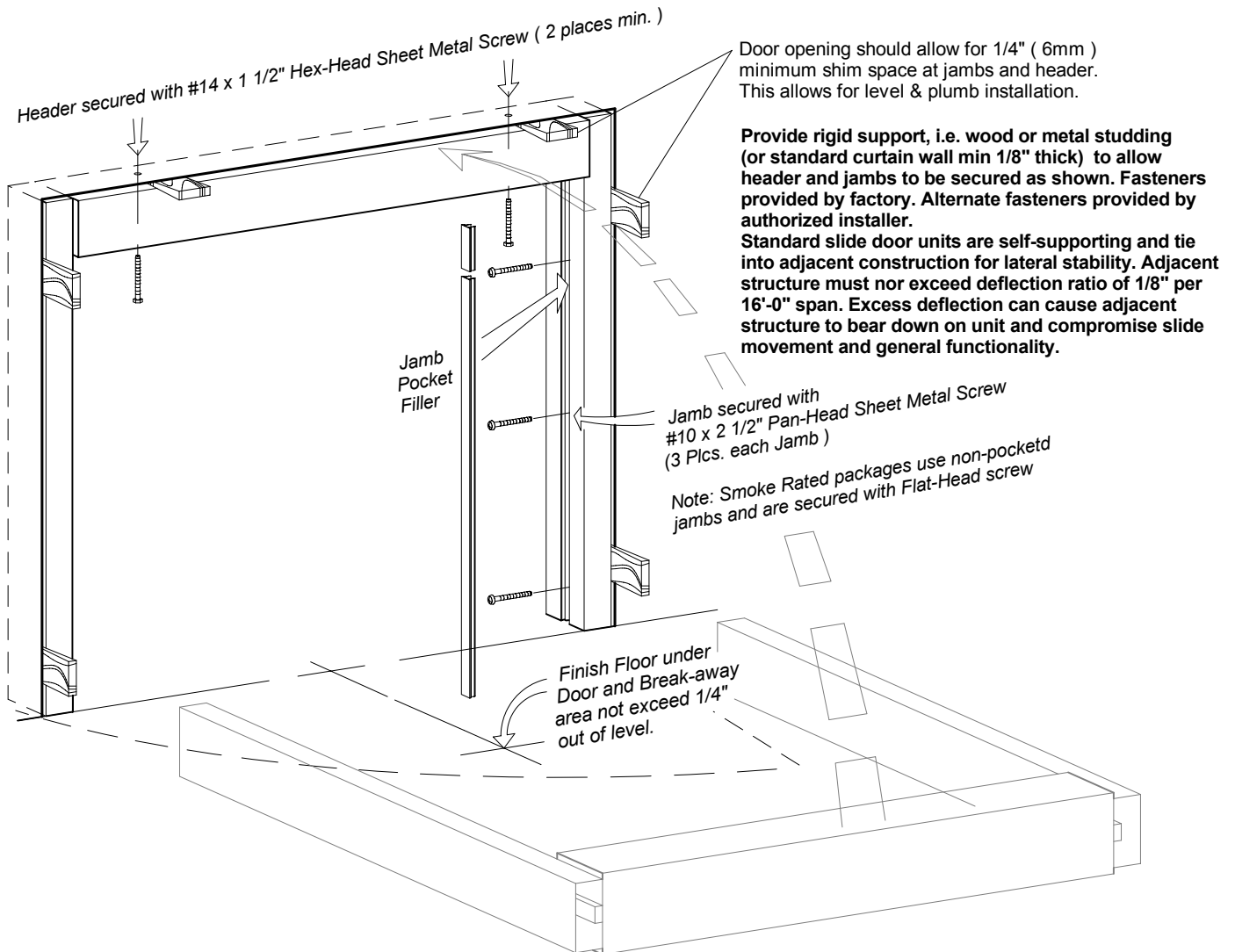

### Typical Floor Mounted Bottom Guide Installation

Floor pivots and bottom guides will vary with the unit type. The basic types are shown below.

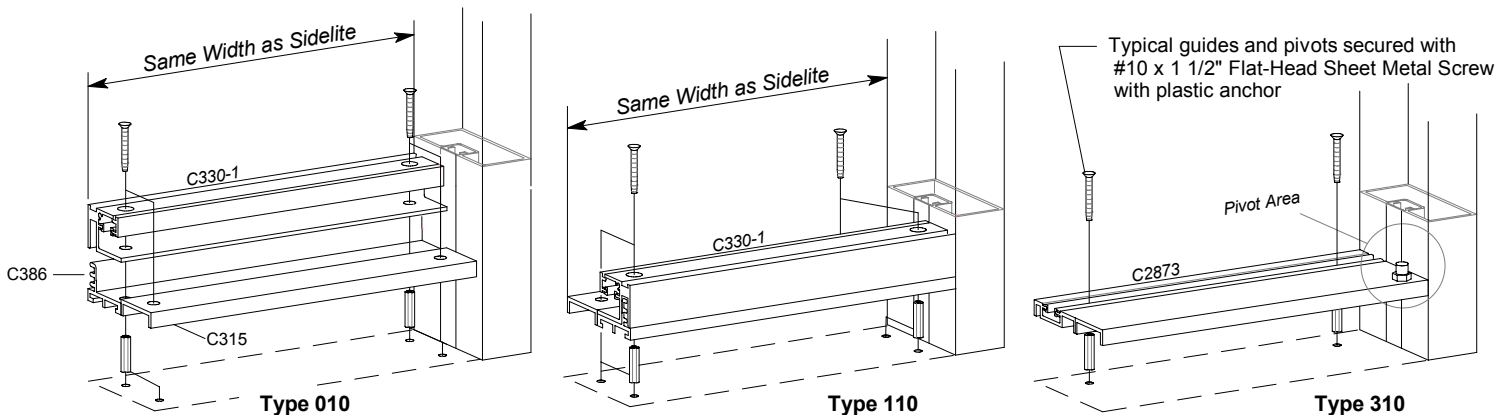

NOTE:  
ALL VIEWED FROM EXTERIOR SIDE.